

GALVANIZED STEEL LL - TECHNICAL DETAILS



GALVANIZED STEEL FRAMES LL FEATURES

Lateral Lever GALVANIZED STEEL projection frames, packed in the desired sizes, are composed of:

- Galvanized steel guides (measures 18x22 mm or 18x32 mm) with splits at top for easy entry of rolling shutter and holes for installation.
- Galvanized steel crossbar (measures 18x22 mm or 18x32 mm).
- Galvanized steel arms.
- Galvanized steel hinges and inner stoppers.
- Screws for installation.

This is recommended for opening widths up to a maximum of 1400 mm.

N.B. The galvanized steel frames have the arms spring locking arms (arm length 570 mm or 470 mm)

HOW TO ORDER:

- Provide window opening measurements:
Opening Width (L) X Opening Height (H).
If Type Rome, specify also additional measures of the right and the left side with respect to the opening width.

TYPE OF ARMS:

- Arms with spring lock of length 470/570 mm

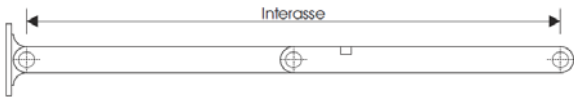

Galvanized steel guide
(measures b x a: 18x22 mm or 18x32 mm)

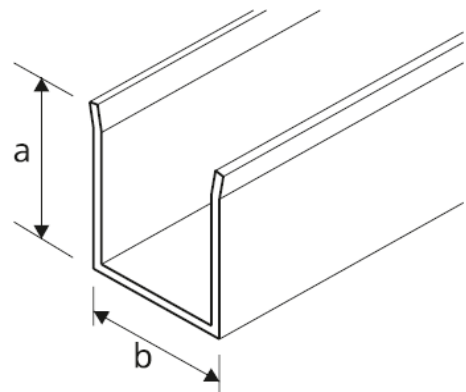

GALVANIZED STEEL LL - TECHNICAL DETAILS

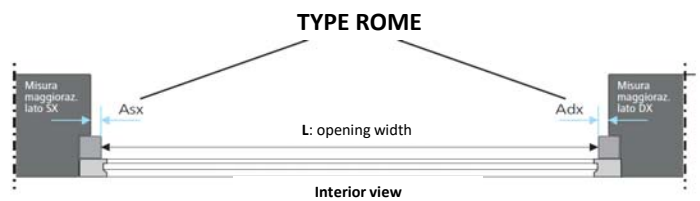
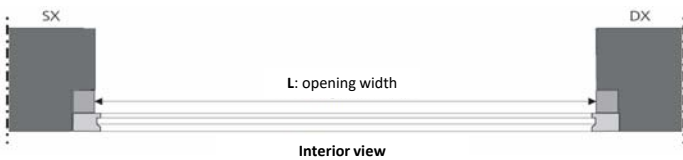
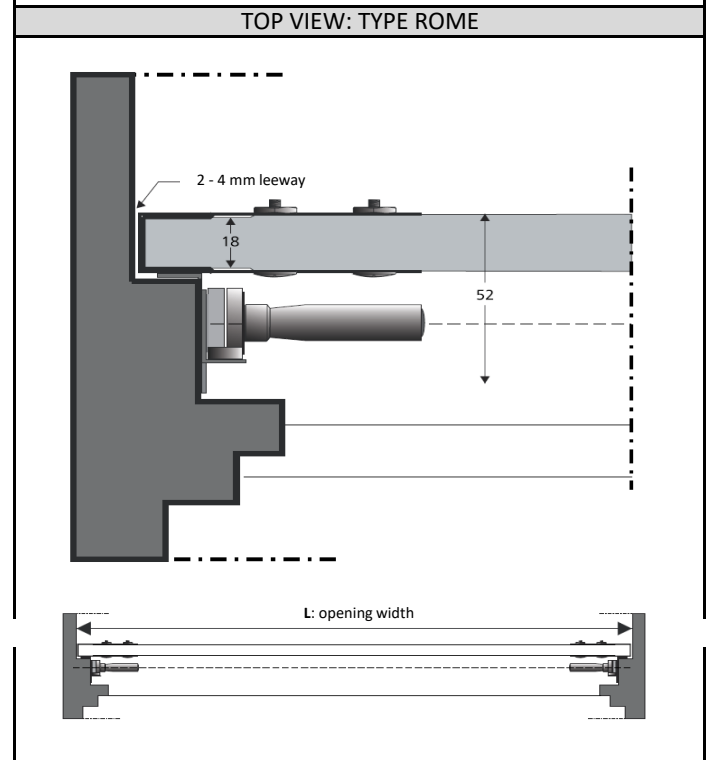
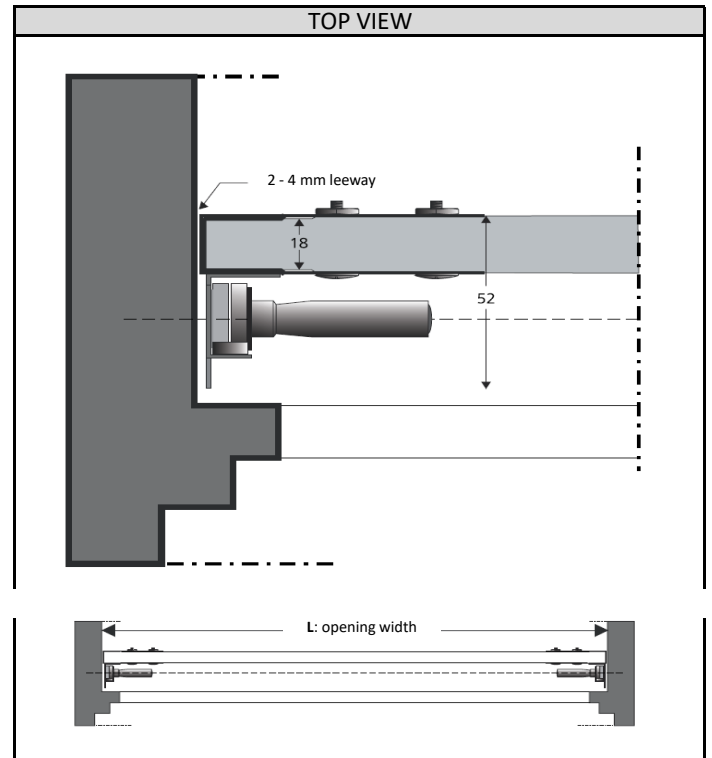
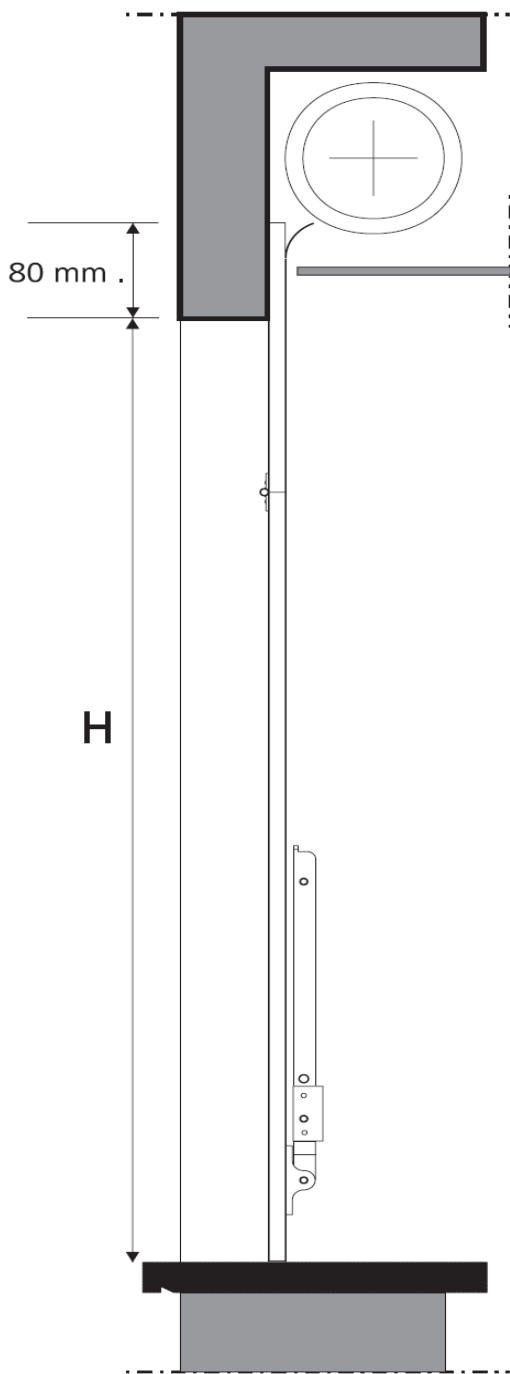

GALVANIZED STEEL LC TECHNICAL DETAILS



GALVANIZED STEEL FRAMES LC FEATURES

Central Lever GALVANIZED STEEL projection frames, packed in the desired sizes, are composed of:

- **Galvanized steel guides (measures 18x22 mm or 18x32 mm)** with splits at top for easy entry of rolling shutter and holes for installation.
- **Galvanized steel crossbar (measures 18x22 mm or 18x32 mm)**. Tubular crossbar on request.
- **Galvanized steel arms, rod and handle.**
- **Galvanized steel hinges and inner stoppers.**
- **Screws** for installation.
- **Nylon rest arms LC.**

This is recommended for windows over 1400 mm in width and up to a maximum of 3000 mm in width.

A double handle and a reinforcement inside the crossbar are installed on the frame for rolling shutters from 2300 mm to 3000 mm wide, unless otherwise specified.

N.B.: The LC frames in galvanized steel are produced without welding between arms and rod: they are connected by a nylon axle box to avoid damaging the galvanization of various components. On request: these frames can be made in the traditional manner with the arms welded onto rod.

HOW TO ORDER:

- Provide window opening measurements:
Opening Width (L) X Opening Height (H).
If Type Rome, specify also additional measures of the right and the left side with respect to the opening width.

TYPE OF ARMS:

- Not welded arms - length 540 mm
- Welded arms - length 470/570 mm

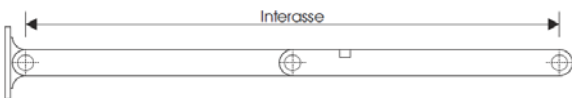

Galvanized steel guide
(measures b x a: 18x22 mm or 18x32 mm)

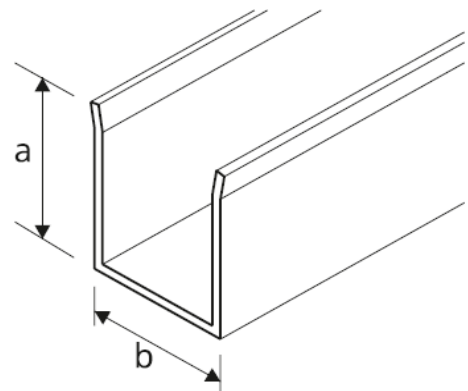

GALVANIZED STEEL LC - TECHNICAL DETAILS

